

## 1. INSTALL TIRES AND FENDERS

- Remove Hub shipping covers and install tires (cone side of lug nuts towards rim).
- Torque lug nuts 70-90 ft lbs. (check periodically to insure torque value is maintained).
- Note tail light quick-connect positions in left and right (curb) fenders. Select and position fenders with quick connects towards the inside. This allows the pre-wired harness to reach the tail lights.
- Bolt fenders to frame with 3/8" x 1" bolts provided in hardware package.
- Connect tail lights (2) to pre-wired harness (3 & 4).

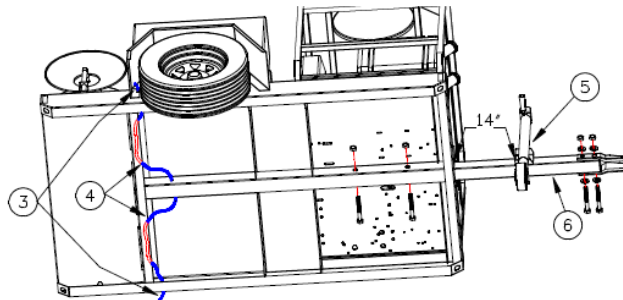
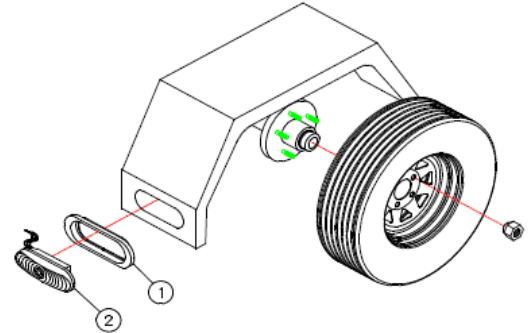

## 2. INSTALL TONGUE & JACK

- Pull tongue (6) from shipping position in frame and fasten with 5/8" x 4 1/2" bolts provided.
- Install bolt into aft most clearance holes.
- Install bolt into forward bolt holes. If necessary, lift tongue to align clearance holes. Install trailer coupler and fasten with 1/2" x 4 1/2" bolts provided. Use 1/2" x 2 1/2" bolts and nylon lock nuts provided for positive safety chain connection to tow vehicle.
- Fasten jack (5) to tongue approximately 14" from the frame.  
Be sure there is sufficient clearance between the jack and frame when jack is swung to horizontal position.

## 3. INSTALL ACCESSORIES

- Remove corner shipping legs and return to Hydro Tek when convenient.
- Install 3/4" Faucet Valve in tank outlet plumbing
- Install Safety red and amber safety reflectors. Amber on front sides and red in rear.

## 4. TRAILER CHECK

- Recheck all bolts and lug nuts to make sure they are tight.
- Fill tank with water and test machine.
- Double check safety chains, coupler latch, jack position and electrical connections before trailering (see operator's manual).